

# T3 51

1

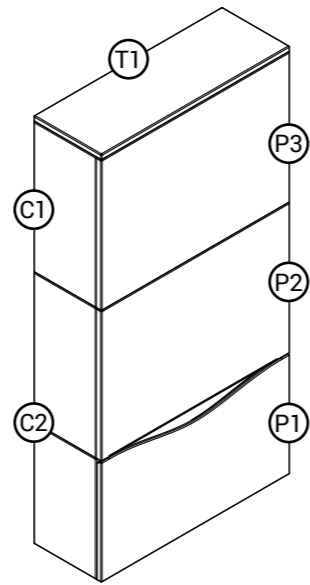

pozi 6 pans SQ

P1 x1

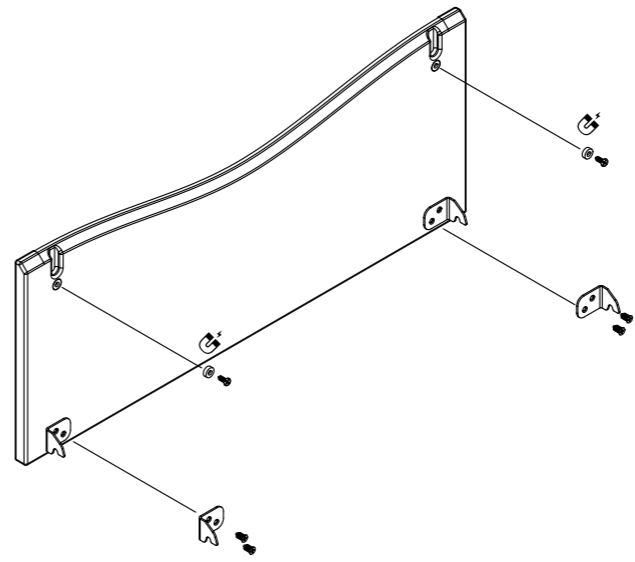

P2 x1

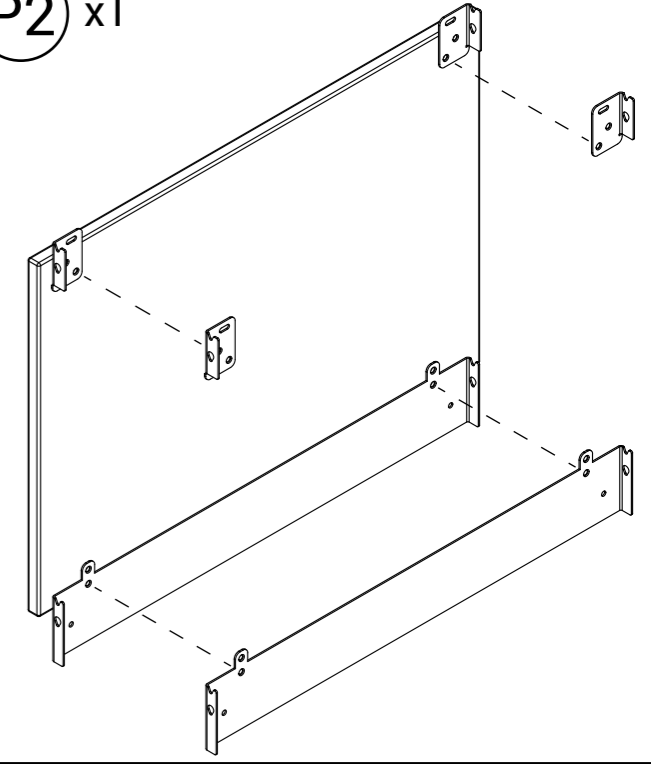

VISSER LES FERRURES SUR LES FAÇADES ET LES CÔTÉS

Version 161025

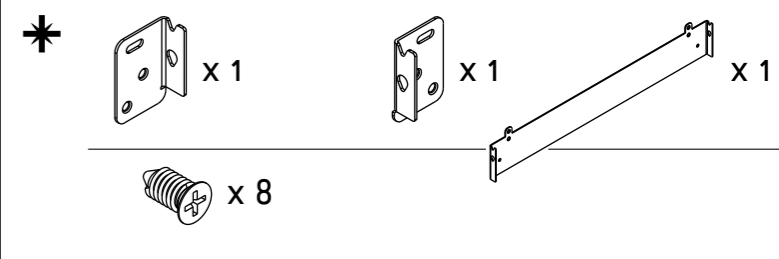
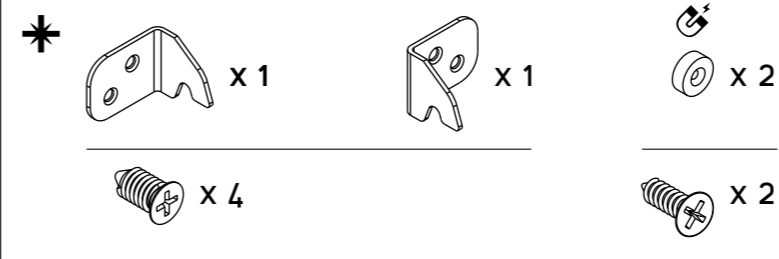

C1 x(1 + symétrique)

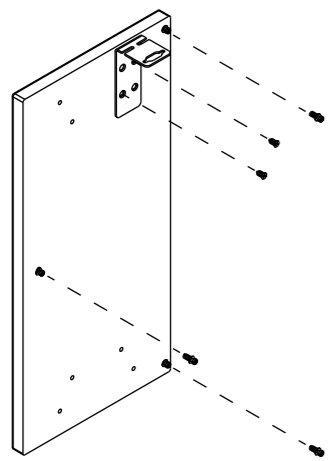

C2 x(1 + symétrique)

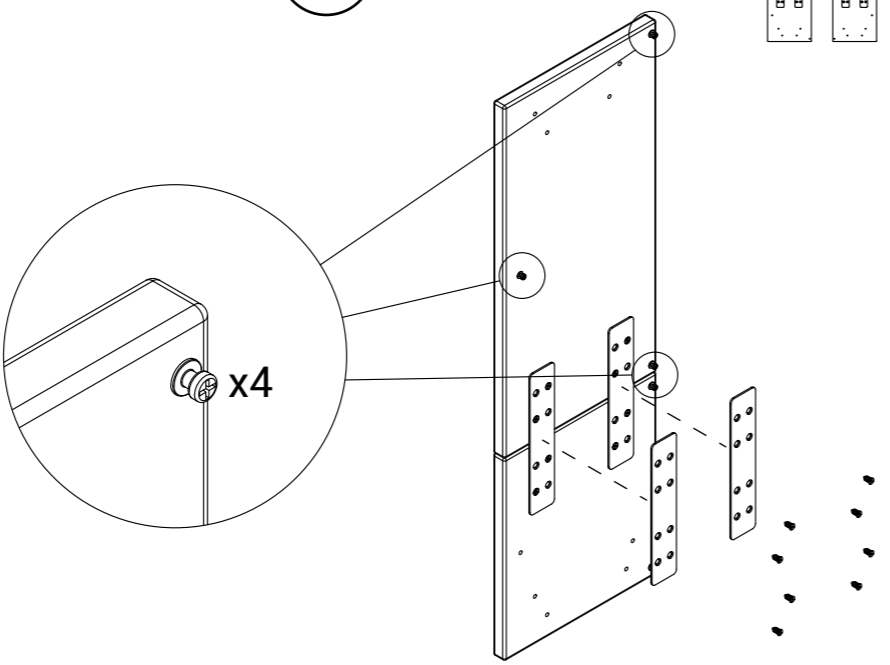

T1 x1

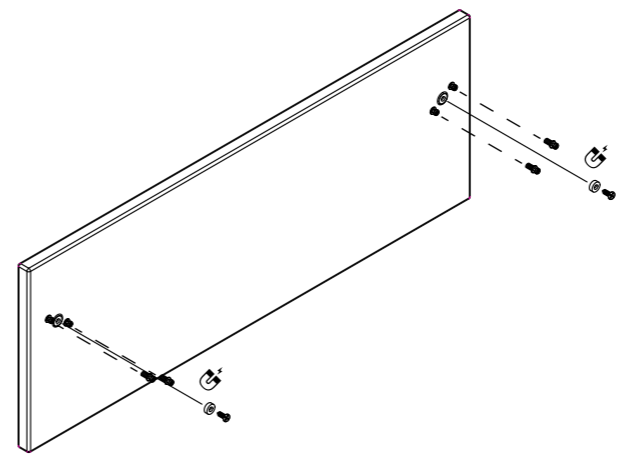

P3 x1

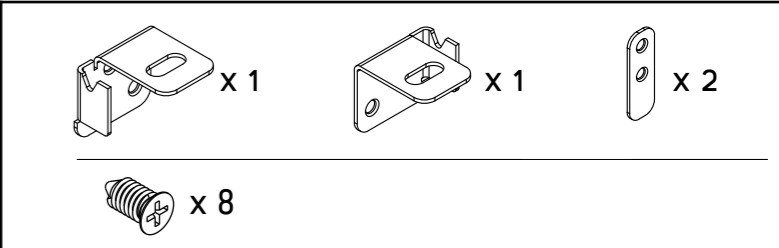
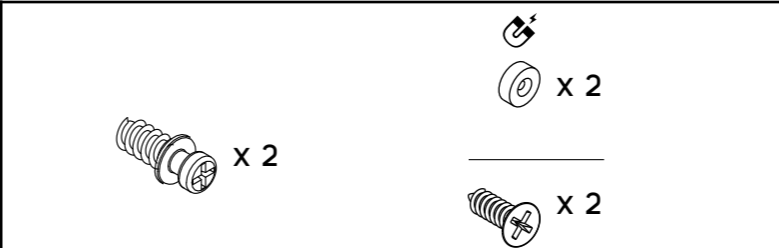
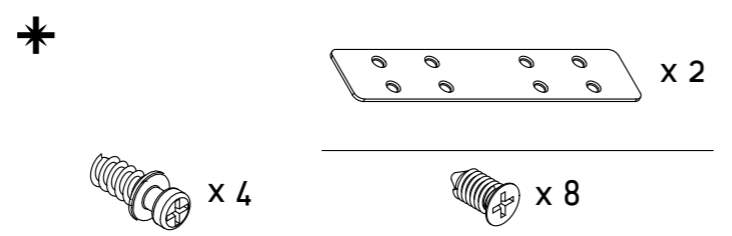
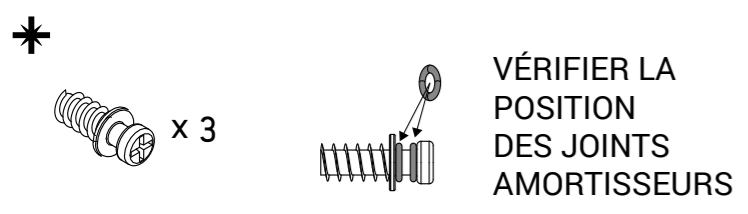
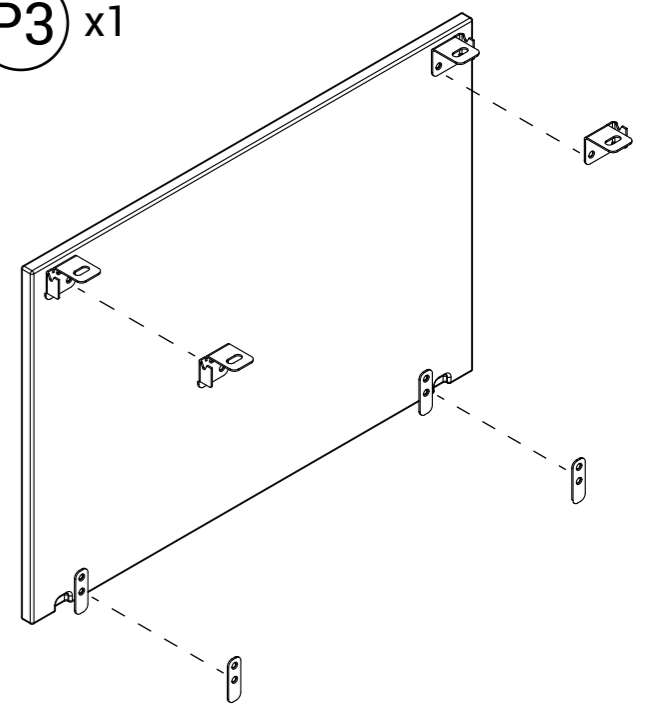

# T3 51



VISSER LES FACADES  
SUR LE CHÂSSIS PUIS  
EMBOÏTER LES COTES

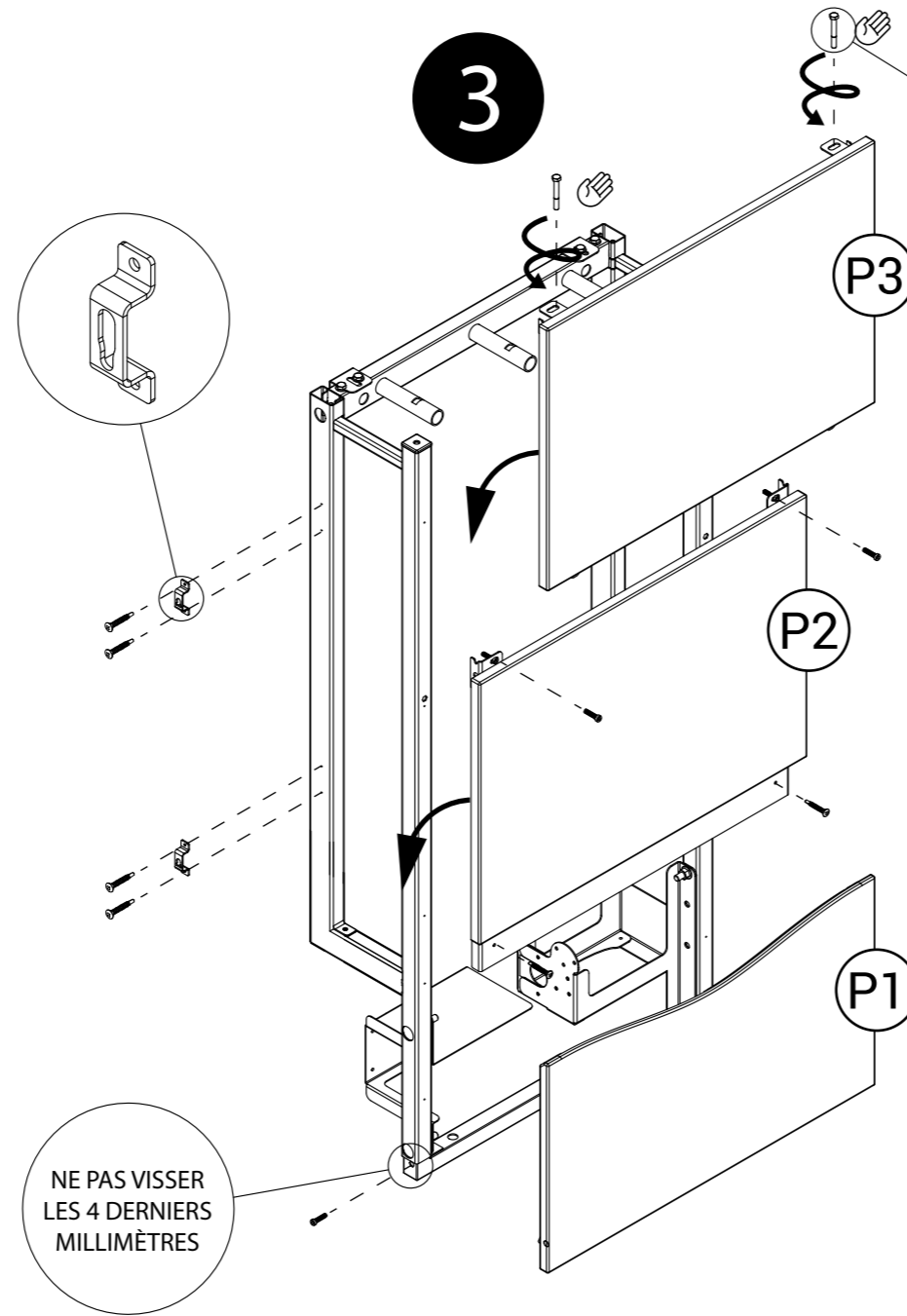
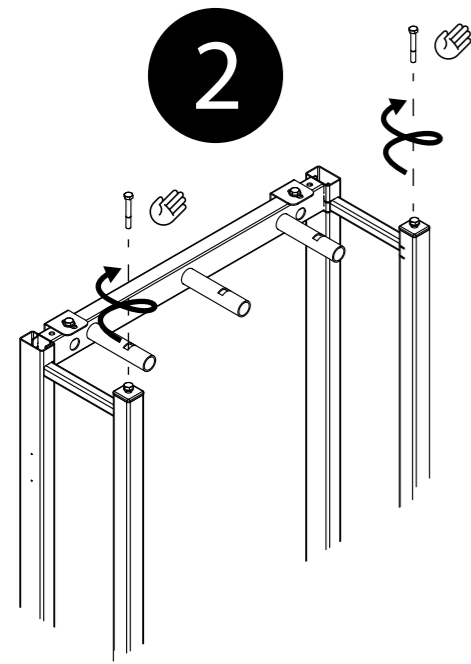

POUR UNE  
INSTALLATION  
ENCASTRÉE  
REPLACER LES VIS  
PAR DES TIGES  
FILETÉES

NE PAS VISSER  
LES 4 DERNIERS  
MILLIMÈTRES

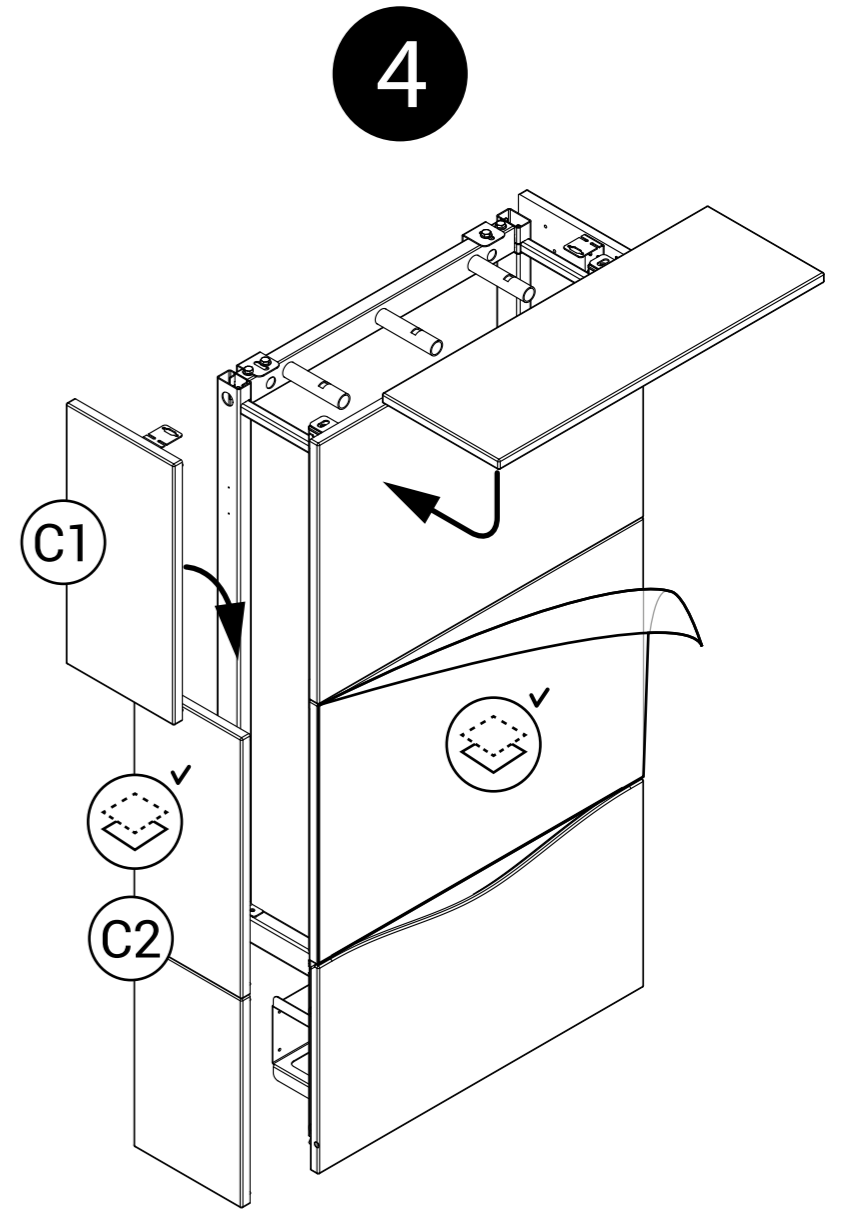

DÉVISER DES POTEUX AVANT  
LES 2 VIS M8 ET LEURS RONDELLES  
LES METTRE DE CÔTÉS POUR L'ÉTAPE 2

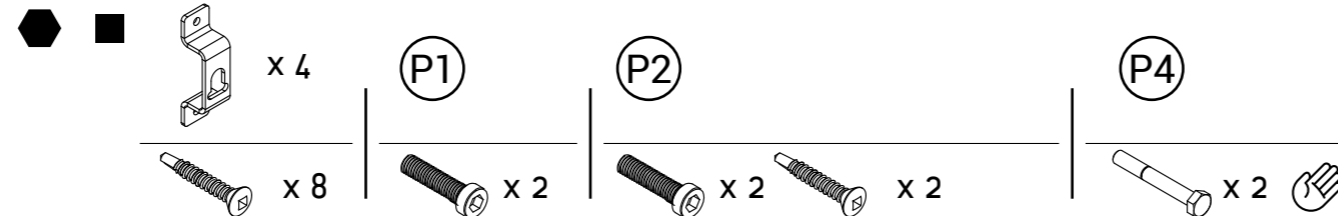
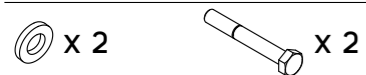

EMBOÏTER MANUELLEMENT  
LES TÊTES DE VIS  
DANS LES FERRURES

